

Eclipse Architectural®
Exterior folding door systems
www.eclipsearchitectural.com



Beautiful doors for beautiful spaces

Eclipse C3 Aluminum Folding Door System

Dealer Brochure 2012

Specifications

C3 Exterior Aluminum Folding Door System (Not thermally broken) with E3C Eclipse Architectural Hardware

In a single direction:

Maximum Panel Weight: 220 lbs (100kg) each panel
Minimum Panel Width: 24" (609mm)
Maximum Panel Width: 39" (990 mm)
Minimum Panel Height: 32" (813mm)
Maximum Panel Height: 120" (3048mm)
C3 Door Thickness: 2-1/4" (57.15mm)
Maximum # of Doors: 8 each way = 16 panels = 52 ft (15.8m) total.

NOTE: When using maximum panel width & height 39" x 120" (990 mm to 3048 mm) panel may exceed maximum panel weight of 220 lbs (100kg). Calculated weight check should be done. Panel heights of 120" (3048mm) and over may fall under the weight restrictions.

C3 Extrusions: Extruded Aluminum 6063-T5.

C3 Extrusion Finishes:

1. a) Clear & b) Bronze anodized finishes are Class 1.
2. a) Standard Mill Finish available for custom colors from Eclipse.
3. a) White Powder Coat finish: D2000-AAMA 2604 (5 year Florida) 15 year MFG's warranty.
4. a) Custom Powder Coat finishes available D3000-AAMA 2605 (10 year Florida) 20 year MFG's warranty.
5. a) Wood Grain finishes (custom): AAMA 2604 (5 year Florida) 10 year MFG's warranty.

E3COM Hardware: Stainless Steel (304SS) Components with Aluminum hinges.

C3 Twinpoint Hardware: Stainless Steel (304SS) & Aluminum Components.

C3 Lever Lock Sets: F-2 Sets Powder Coat over Brass.

DSD Multi-point Door Locks: Faceplate, latch and hooks are 304SS.

3 Standard Frame & Door Panel Finishes:

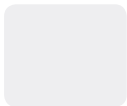

White Powder Coat



Clear Anodized



Bronze Anodized

Custom finishes available on our website: www.eclipsearchitectural.com

Call for manufacturing time.

- 19 Custom Wood Grain finishes available (not shown)
- 31 Solid Colors: Custom powder coat finishes available (not shown)
- 18 Metallic Custom Powder coat finishes available (not shown)

Choose from hundreds of configurations,
some examples below:

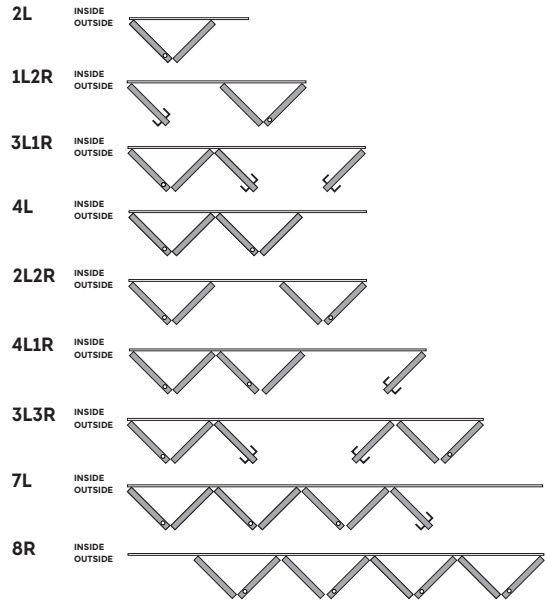

PLEASE NOTE: For technical reasons associated with color reproduction, the colors shown on this brochure give only an indication of color & finish. No warranty or guarantee can be given that they will exactly match the product as supplied.

Eclipse Warranty

The Eclipse program is a complete product offering. Component deletions and/or substitutions are strictly prohibited. Warranty is void if system has missing or substitute products. Please refer to www.thehdsgroup.com/terms for our full warranty information, terms & conditions, returns & allowances, claims policy, and other general information.

Top 10 Cool Custom Features of our Folding Door System

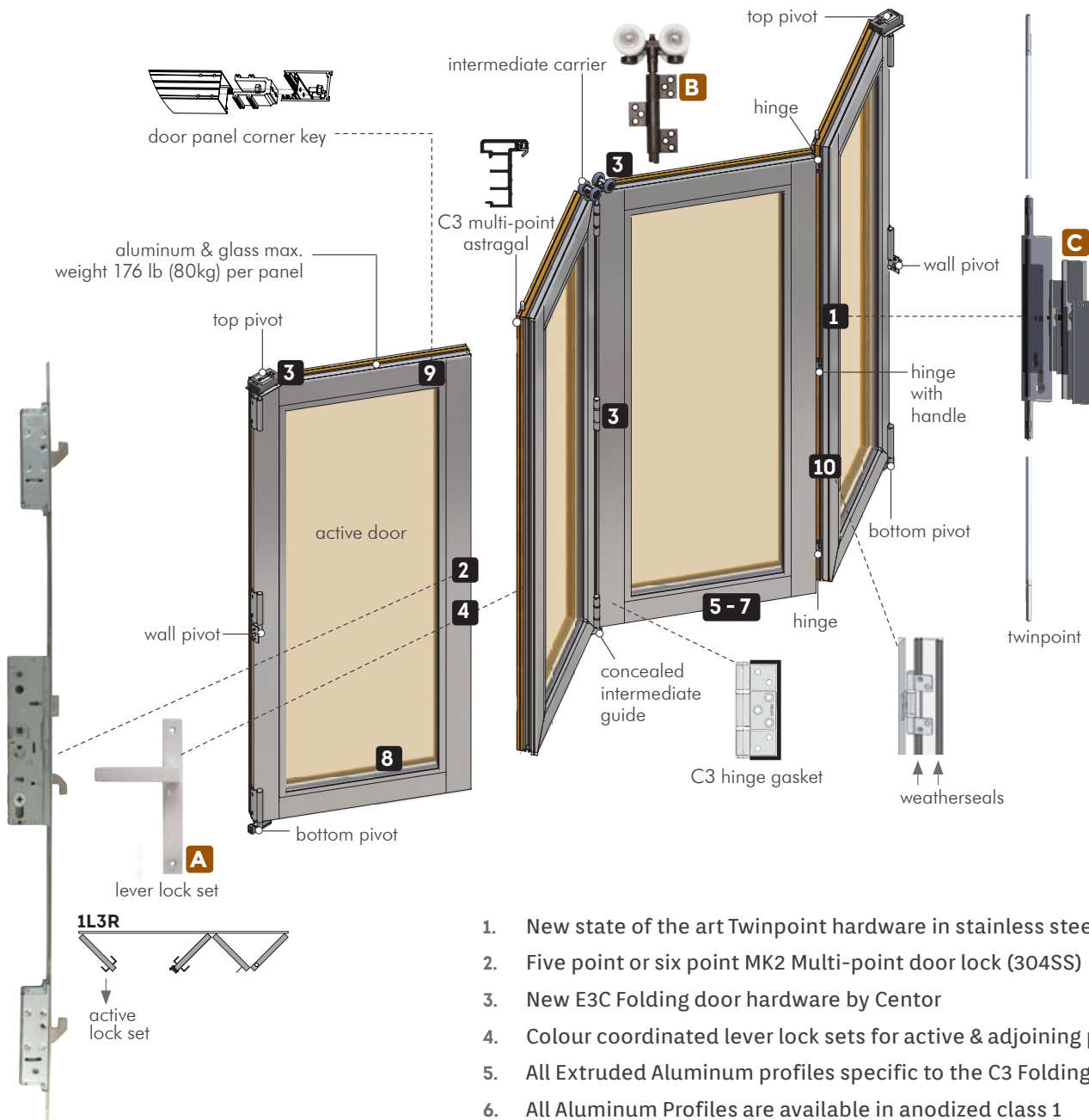

Multi-point Door Lock

- (3 hooks) + top & bottom shootbolts = 5 point
- 3 Hook Model for door heights of up to 95-15/16" (2437 mm)
- 4 Hook Model for door heights of 96" (2438.4mm) or over.

1. New state of the art Twinpoint hardware in stainless steel (304SS)
2. Five point or six point MK2 Multi-point door lock (304SS)
3. New E3C Folding door hardware by Centor
4. Colour coordinated lever lock sets for active & adjoining panels
5. All Extruded Aluminum profiles specific to the C3 Folding Door System
6. All Aluminum Profiles are available in anodized class 1
7. All Aluminum Profiles are available in Powder Coat finishes (custom)
8. Door panels designed to hold S.G., I.G. or H.G.
9. Door Panel Corner Key makes for easy assembly
10. Dual weatherseals on head, jamb, sill & between each panel

A Lever Lock Set **B** Carrier & Hinge **C** Twinpoint Handle

A, B & C available in white, satin, black & bronze powder coat finishes.

NO SCALE

C3 Cross Section

Outswing (System Tested 3LIR) (Not thermally broken)

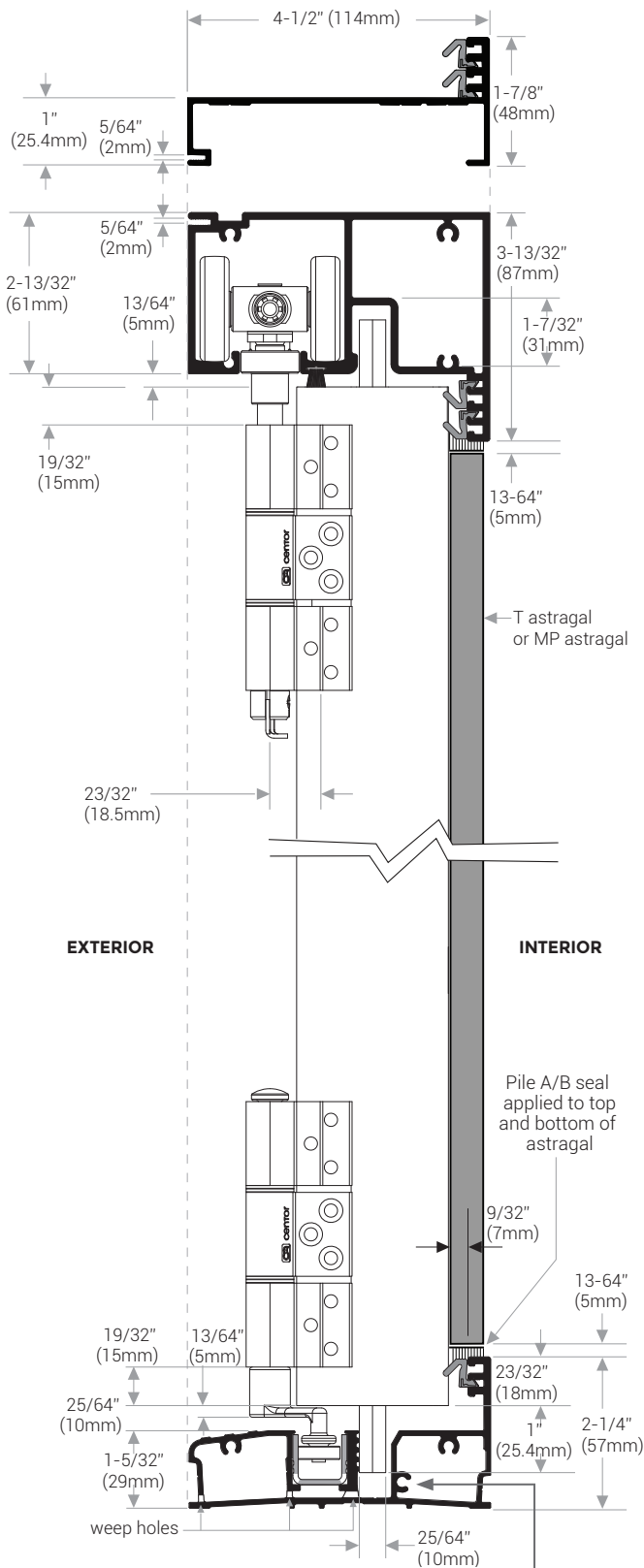

Inswing

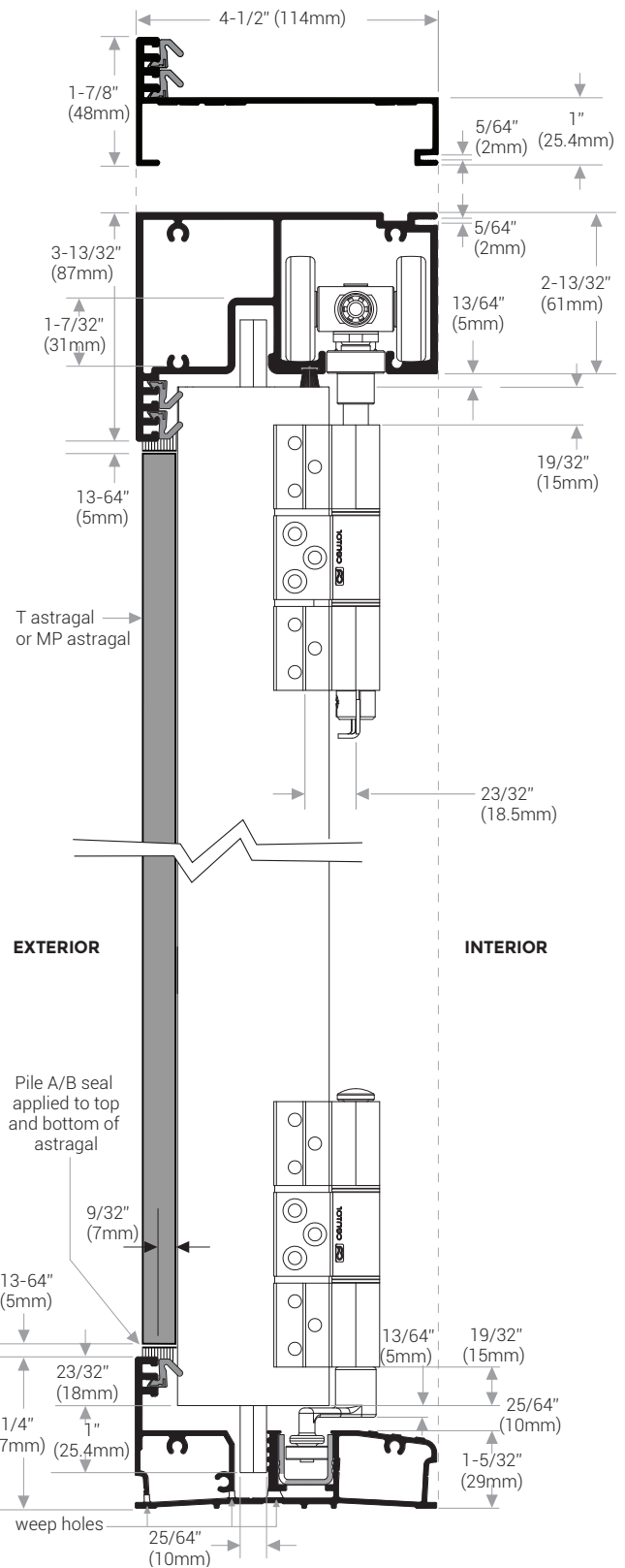

Panel to Sill Detail

NO SCALE



DF3 (Aluminum TwinPoint Swing Handle) Finishes • DF4 Finishes (On Stainless Steel)

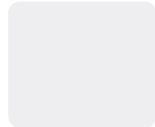

White Powder Coat



Satin Aluminum Powder Coat



Black Powder Coat



Bronze Powder Coat

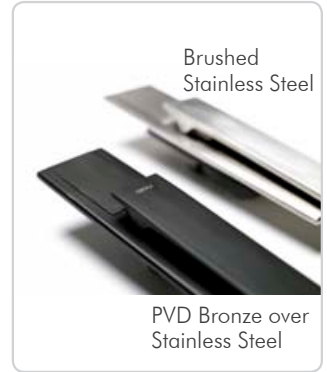

4L



Twinpoint & Swing Handle

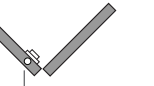

Twinpoint & Swing Handle

3L

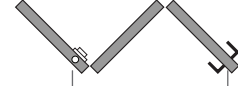

Twinpoint & Swing Handle



Multipoint & Lever Lock Set

Twinpoint assembly is used in securing each pair of folding panels in the closed position. Not used on the swing (active) panel.



Ferraro 2 Series Lever Lock Set

Available Finishes: (Powder Coat over Brass)

- White Powder Coat
- Satin Aluminum Powder Coat
- Black Powder Coat
- Bronze Powder Coat

Multi-point Door Lock



E3C Intermediate Carrier (shown)

Available Finishes (Hinges):

- White Powder Coat
- Clear Anodized Aluminum (Satin)
- Black Powder Coat
- Bronze Powder Coat

PLEASE NOTE: For technical reasons associated with color reproduction, the colors shown on this brochure give only an indication of color & finish. No warranty or guarantee can be given that they will exactly match the product as supplied.

NO SCALE

Glazing Details

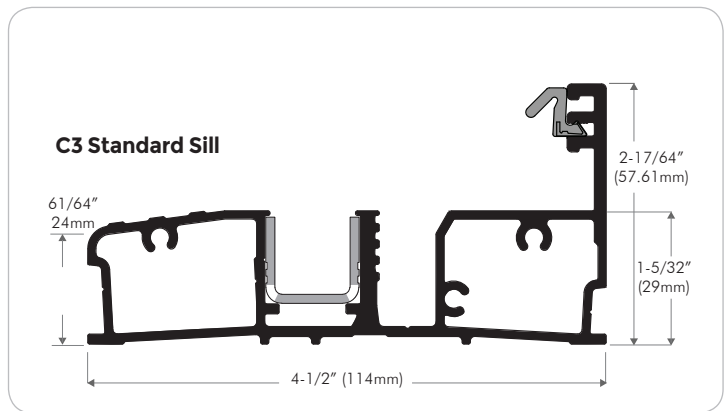
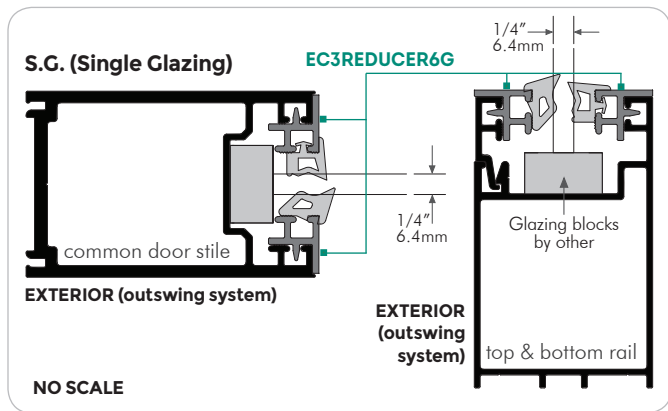
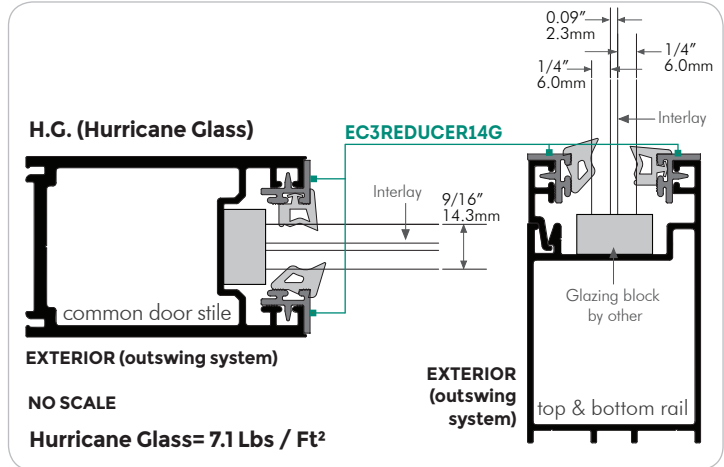
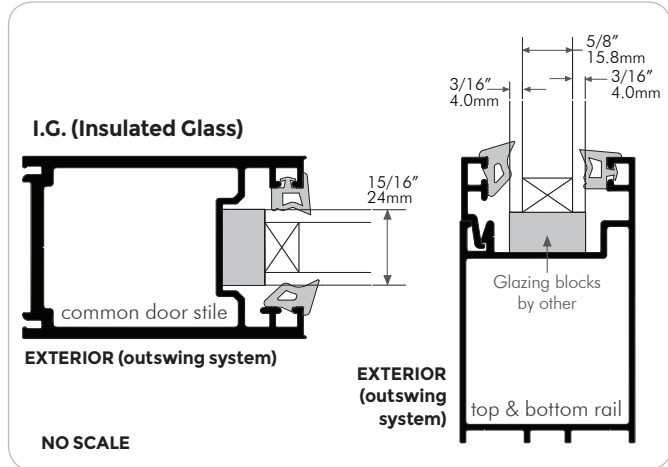

C3 Optional Panel to Sill Details, Cross Section View (outswing) • Panel to sill (water return) detail shown on page 4.

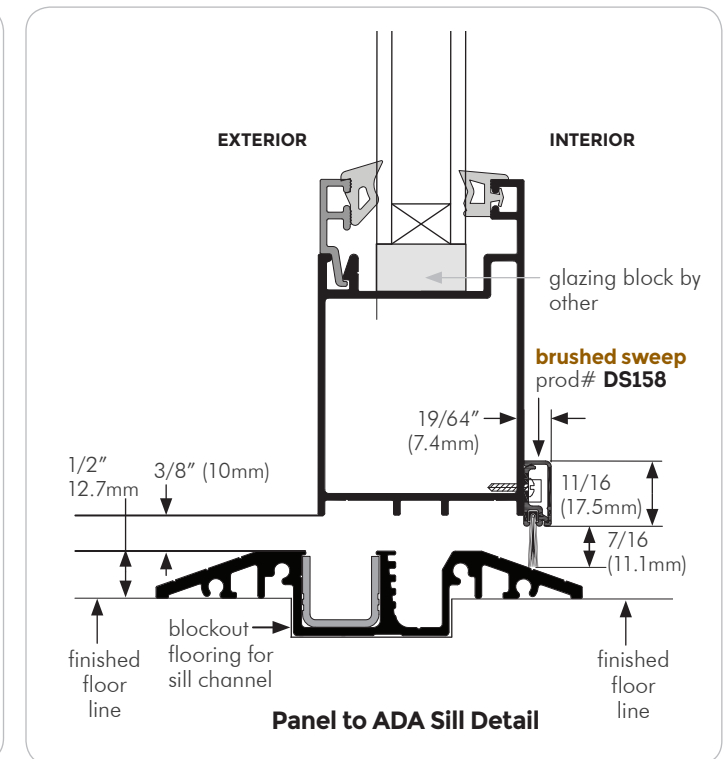
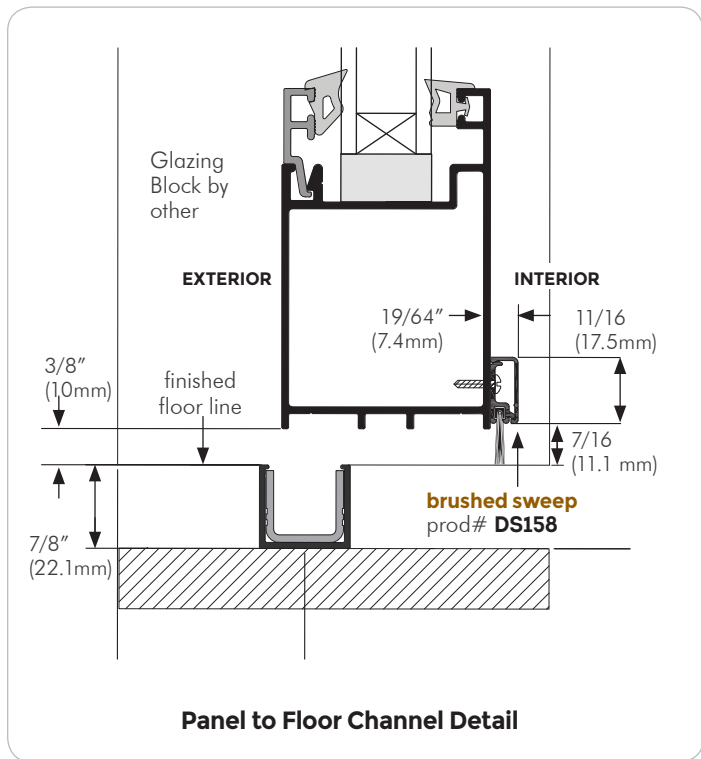

HALF SCALE EXCEPT AS NOTED





Test Performance • Met all requirements

3LIR Outswing System
CAN / CGSB 82.1-M89
Air: A2
Water Leakage Resistance: B4 (510 PA)
Wind Load Resistance: C3

AAMA / WDMA / CSA 101 / I.S.2 / A440-08 • NAFS-08
Air Infiltration: A2
Water Leakage Resistance: DP70 (510 PA) or PG70 • C3 Storm 45, 70, series and C3 H100 series
Wind Load Resistance: DP70 (3360 PA) (Enhanced System) or PG70 • C3 Storm 70 Series
Wind Load Resistance: DP45 (2160 PA) (Standard System) or PG45 • C3 Storm 45 Series
Wind Zone 4 (Hurricane) ASTM (cycling) E1996: DP100 (C3 H100 Series)
Wind Zone 4 (Hurricane) ASTM (impact) E1886: Pass (C3 H100 Series)

For full test results, please visit www.eclipsearchitectural.com

Authorized Fabricator / Distributor



2406 Canoe Ave, Coquitlam BC V3K 6C2
P. (604) 941-6693 F. (604) 941-6694
www.woodwindows.ca